

NO.	PART NAME	MATERIAL
1	BODY	CARBON STEEL
2	BASKET	
	PERF. DIA.	
	MESH	
3	O-RING	BUNA-N
4	COVER	CARBON STEEL
5	BOLTS	A 325
6	NUTS	A 193 B7

PIPE SIZE (NOMINAL)	DIMENSIONS						F (NOM.) IN. MM	APPROX. WEIGHT LBS. KG	PART NO.
	A IN. MM	B IN. MM	C IN. MM	D IN. MM	E IN. MM				
2 (50mm)	14.00 / 356	12.00 / 305	8.63 / 219	6.63 / 168	26.00 / 660	1/2 (15)	71 / 32.2	ST090020BR3TA	
3 (80mm)	15.00 / 381	12.50 / 318	8.63 / 219	6.63 / 168	26.00 / 660	1/2 (15)	90 / 40.8	ST090030BR3TA	
4 (100mm)	16.00 / 406	14.00 / 356	9.50 / 241	8.63 / 219	29.00 / 737	1 (25)	155 / 70.3	ST090040BR3TA	
5 (125mm)	16.00 / 406	15.00 / 381	11.25 / 286	10.75 / 273	33.00 / 838	1 (25)	205 / 93.0	ST090050BR3TA	
6 (150mm)	20.00 / 508	17.00 / 432	11.25 / 286	10.75 / 273	35.00 / 889	1 (25)	220 / 99.8	ST090060BR3TA	
8 (200mm)	22.00 / 559	21.00 / 533	13.00 / 330	12.75 / 324	42.00 / 1067	1-1/2 (40)	305 / 138.4	ST090080BR3TA	
10 (250mm)	32.00 / 813	25.00 / 635	15.75 / 400	16.00 / 406	50.00 / 1270	1-1/2 (40)	500 / 226.8	ST090100BR3TA	
12 (300mm)	35.00 / 889	28.00 / 711	17.75 / 451	18.00 / 457	56.00 / 1422	1-1/2 (40)	665 / 301.6	ST090120BR3TA	
14 (350mm)	37.00 / 940	33.00 / 838	19.75 / 502	20.00 / 508	65.00 / 1651	2 (50)	810 / 367.4	ST090140BR3TA	
16 (400mm)	42.00 / 1067	36.00 / 914	23.25 / 591	24.00 / 610	74.00 / 1880	2 (50)	1060 / 480.8	ST090160BR3TA	
18 (450mm)	42.00 / 1067	39.00 / 991	23.25 / 591	24.00 / 610	76.00 / 1930	2 (50)	1110 / 503.5	ST090180BR3TA	
20 (500mm)	43.00 / 1092	44.00 / 1118	27.75 / 705	30.00 / 762	88.00 / 2235	2 (50)	1610 / 730.3	ST090200BR3TA	
24 (600mm)	48.00 / 1219	60.00 / 1524	27.75 / 705	30.00 / 762	102.00 / 2591	2 (50)	1900 / 861.8	ST090240BR3TA	

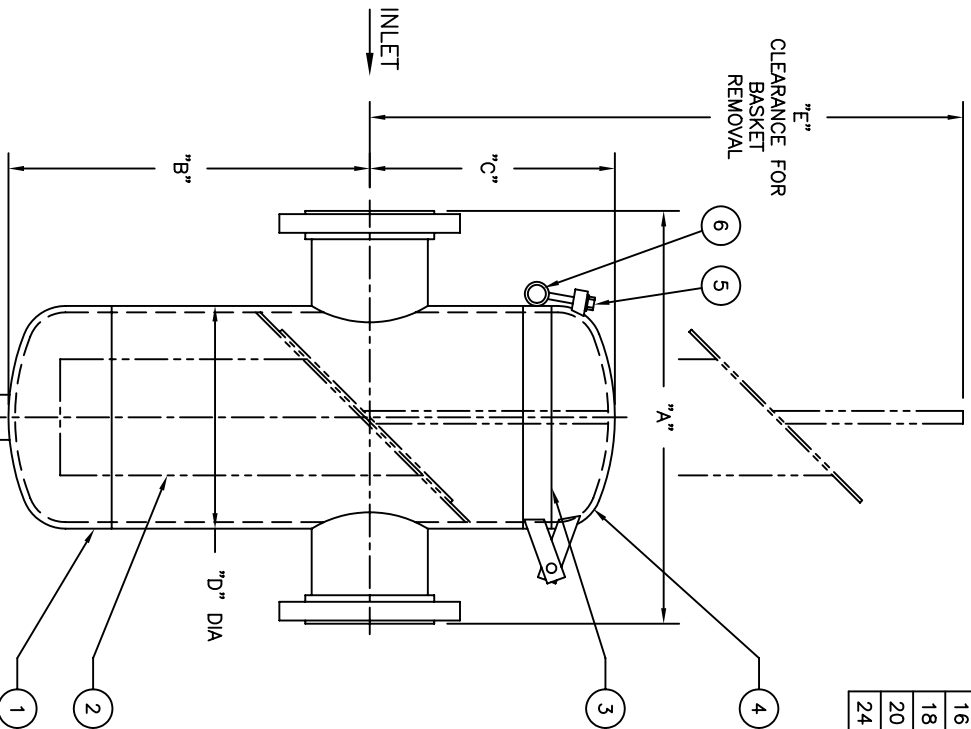

NOTES :

- UNITS ARE DESIGNED IN ACCORDANCE WITH ASME SECT. VIII, DIV. I OF BOILER PRESSURE VESSEL. CODE & IN COMPLIANCE TO CURRENT PUBLISHED ADDENDA .
- CODE STAMPED VESSEL AVAILABLE.
- ALL DIMENSIONS ARE IN INCHES / MM.
- INLET / OUTLET FLANGES PER ANSI B16.5.
- ALL BOLT HOLES STRADDLE NATURAL CENTERLINES.
- DESIGN PRESSURE : 150 PSIG @ 150° F  
(10.3 BAR @ 65.6°C)  
MDMT : -20°F @ 150 PSIG  
(MDMT : -28.9°C @ 10.3 BAR)

CERTIFIED FOR:

P.O. NO. :  
REG. NO. :  
QUOTE NO. :  
TAG NO. :

ELECTRONIC FILE NAME: SD090QC1.DWG  
REF. ECR D507 DATE 11/1/05

UNAUTHORIZED USE, MANUFACTURE OR REPRODUCTION IN WHOLE OR IN PART IS PROHIBITED. DRAWING, DESIGN AND OTHER DISCLOSURES PROPERTY OF EATON FILTRATION, LLC

		DRAWN		DATE		GERT.		DATE		REV	
		FM	1/5/98	LF	1/5/98	B					
<b>EATON FILTRATION, LLC</b> 900 FAIRMOUNT AVENUE, ELIZABETH, NEW JERSEY 07207		MODEL 90 BASKET STRAINER 150# RF FLANGE / QUICK OPENING COVER SIZES 2" THRU 24" CARBON STEEL									
NAME SD090QC1											